

Safety Information

The following safety symbols are used in this manual for user's safety. Read this manual carefully and follow all instructions to avoid property damage, re, explosion, personal injury, or death.

- Do not store or use gasoline or other ammable vapors and liquids in the vicinity of this or any other appliance.
- What to do if you smell gas
 - Do not try to light any appliance.
 - Do not touch any electrical switch; do not use any phone in your building.
 - Immediately call your gas supplier from a neighbor's phone. Follow the gas supplier's instructions.
 - If you cannot reach your gas supplier, call the re department.
- Installation and service must be performed by a licensed professional.
- Follow all local codes and/or the most recent edition of the National Fuel Gas Code (ANSI Z223.1/NFPA 54) in the USA, or the Natural Gas and Propane Installation Code in Canada (CAN/CGA B149.1).

Before Installation

Choosing an Installation Location

When considering a location for installation, read "Installing the Water Heater" in the Installation Manual.

Checking the Clearances

Clearances

The water heater should be installed in an area that allows for service and maintenance access to utility connections, piping, lters, and traps. Ensure the following clearances are maintained:

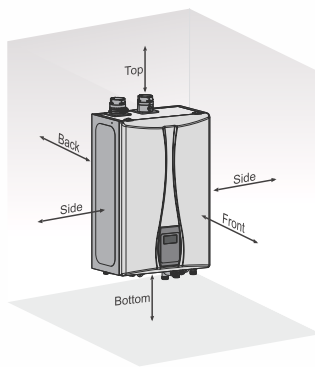

Clearance From	Wall Mounting
Top	12 inches (305 mm) min.
Back	0.6 inches (15 mm) min.
Front	6 inches (152 mm) min.
Sides	3 inches (76 mm) min.
Bottom	12 inches (300 mm) min.

Installation

Opening the Box

The following items are included with the water heater. Check each of the following items before installation.

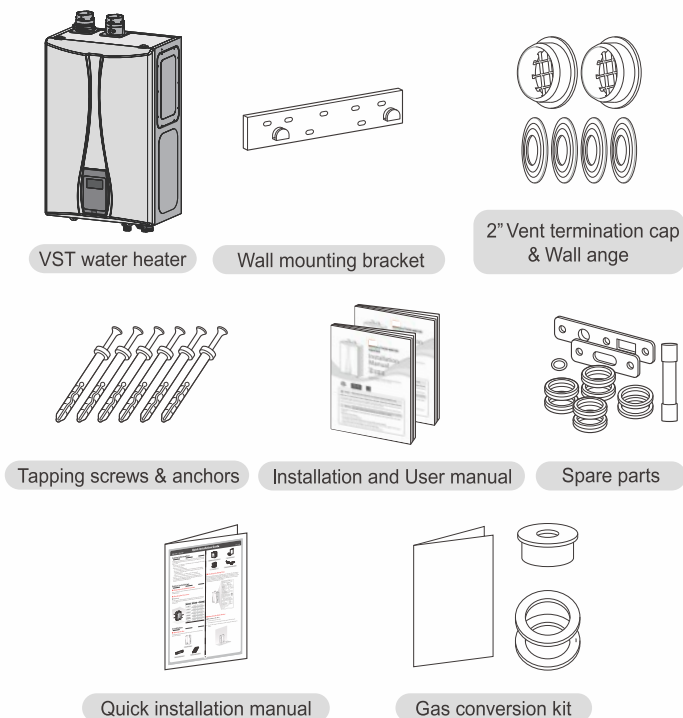

Checking the Rating Plate

Before the installation, check the rating plate located on the side of the water heater to ensure that the water heater matches the gas type, gas pressure, water pressure, and electrical supply available in the installation location. If the water heater does not match each of these ratings, do not install the water heater. If the gas conversion is required, the included gas conversion kit must be used.

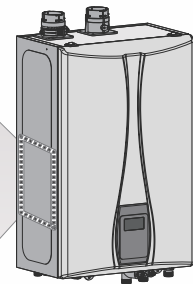
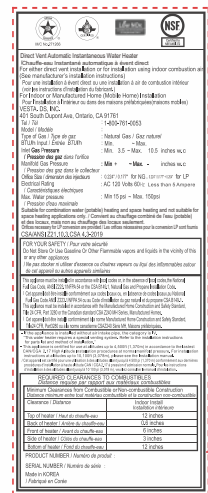

Mounting the Water Heater

Mounting to the wall

To mount the water heater to the wall:

- 1 Check that the wall is level and can support the weight of the water heater.
- 2 Ax the mounting bracket securely to the wall.
- 3 Align the grooves on the back of the water heater with the tongues on the mounting bracket and hang the water heater from the bracket.

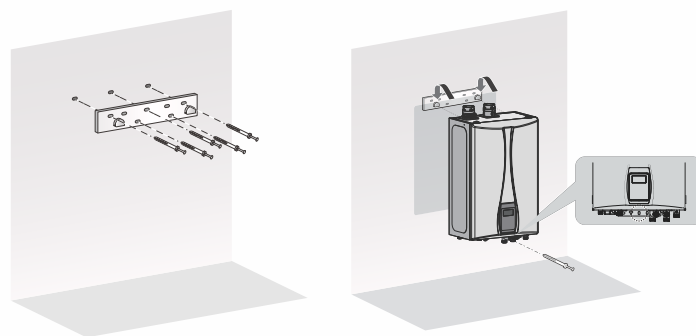

Connecting the Gas Supply

- 1 Connect the gas supply line

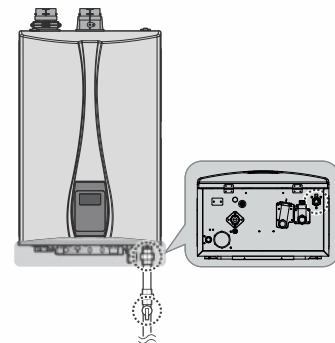

- 2 Check for gas leaks at all joints.

Notice

- Tighten the water heater connection valves with care to avoid damage.
- Apply gas leak detection solution to all gas ttings.
- The minimum internal diameter required for any appliance connector is 3/4".
- When using exible gas lines, ensure that the pipe's inner diameter and connector is sucient to supply the required BTUs. Also, ensure that the exible line has no crimps or tight bends in it, as this will restrict gas ow.
- To facilitate any future maintenance or service, the installation of a union on the gas supply line close to the water heater is recommended.

Connecting the Water Supply

- The following is a water piping example for the water heater:



Make sure to install a mixing/tempering valve in your water system in order to protect against injury. When it is required by your local plumbing code or regulation, you must install a mixing/tempering valve accordingly.

[VTP]

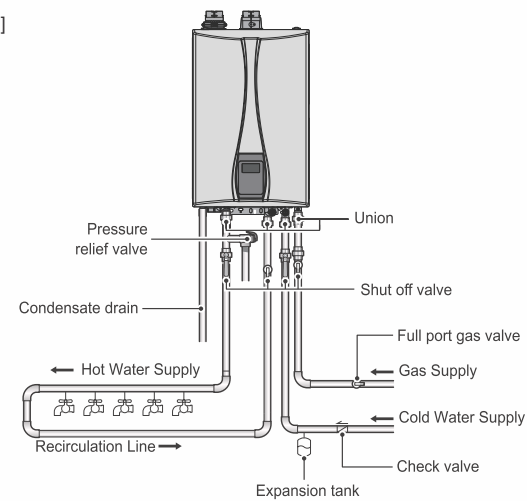

- The following is a water piping example for the water heater:

[VTS]

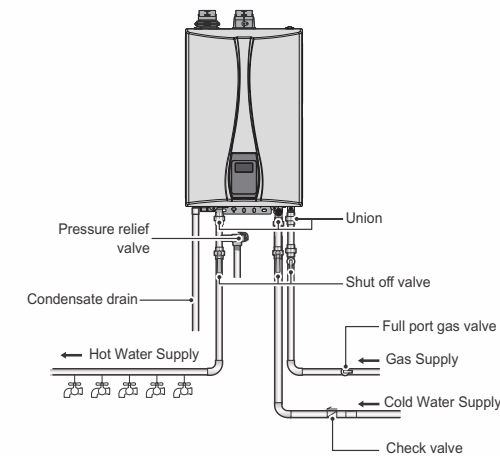

Connecting the Pressure Relief Valve



Improper installation of the pressure relief valve may result in property damage, personal injury, or death. Follow all instructions and guidelines when installing the pressure relief valve. Only a licensed professional should install the valve.



The pressure relief valve must conform to the current edition of ANSI Z21.22 or CAN 1-4.4 and installation must follow local codes.

This water heater does not come with an approved pressure relief valve. To complete the installation of the water heater, you must install an approved 3/4", maximum 150 PSI pressure relief valve on the pressure relief valve connector.

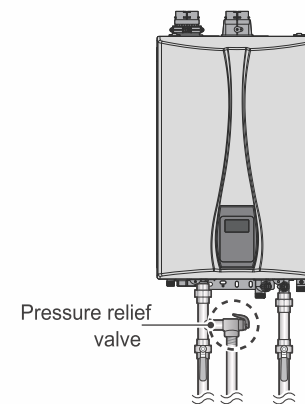

Notice

In recirculating system, install the pressure relief valve on the hot water outlet. The pressure relief valve should be placed as close to the water heater as possible. NO other valve should be placed between the pressure relief valve and the water heater.

Connecting the Condensate Drain

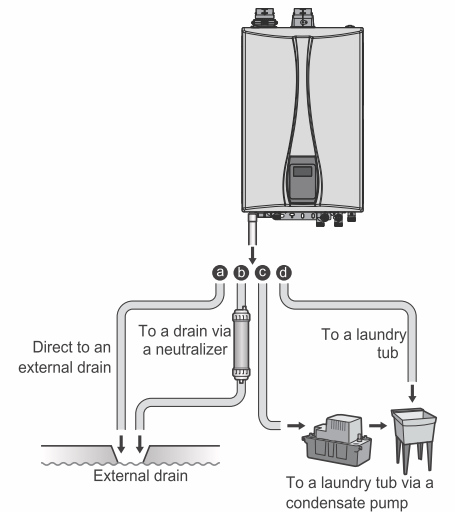

- From the water heater directly into an external drain.
- From the water heater, through a neutralizing agent, and then into an external drain.
- From the water heater into a condensate pump, and then into a laundry tub.
- From the water heater into a laundry tub.

Condensate Trap

Before operating the water heater, ll the condensate trap with water through the ue connector. The water heater may be severely damaged unless lled with water prior to operation. Pour 0.1 gallon (400 ml) of water into the exhaust duct. Deate air suciently or equip the air vent with an outlet pipe prior to lling the condensate trap with water (there must be no air inside the heat exchanger).

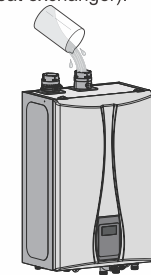

Installing a Vent

Vent Leng

Vent Size	Maximum Length	Maximum # of Elbows	Equivalent Lengths
2"	60' (18 m)	6	Reduce the maximum vent length accordingly for each elbow used: <ul style="list-style-type: none"> • Each 90° elbow equates to 8 linear feet (2.4 m) of vent • Each 45° elbow equates to 4 linear feet (1.2 m) of vent
3"	150' (45 m)	8	Reduce the maximum vent length accordingly for each elbow used: <ul style="list-style-type: none"> • Each 90° elbow equates to 5 linear feet (1.5 m) of vent • Each 45° elbow equates to 3 linear feet (0.9 m) of vent

Connecting the Vent Clip



To connect the exhaust vent rmlly, must use the vent clip included with water heater.

To connect the vent clip:

- 1 Connect the exhaust vent and the vent clip to the ue connector.
- 2 Tighten the screws and fix the vent clip.

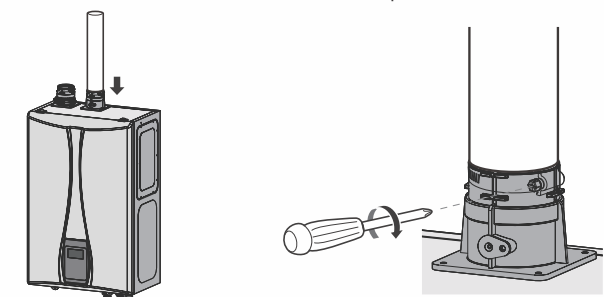

Two-pipe sidewall venting

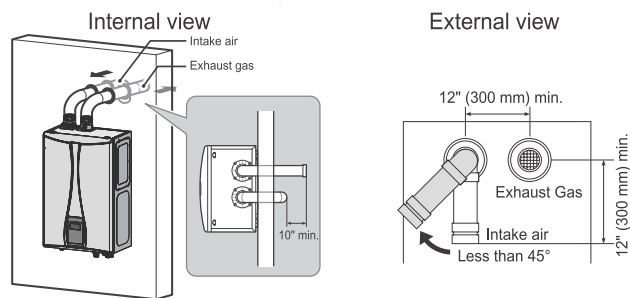

- Caution** Maintain 12" (300 mm) min. (18" (450 mm) min. for Canada) clearance above highest-anticipated snow level. Maximum of 24" (600 mm) above roof.
- Install a bird screen at the end of the intake air pipe and exhaust pipe.

Notice

It is recommended to install the intake air vent terminal as far from the exhaust gas vent terminal as possible.

Non-concentric sidewall venting

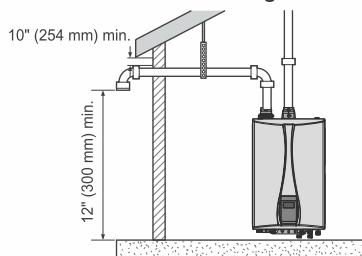

- Caution** Maintain 12" (300 mm) min. (18" (450 mm) min. for Canada) clearance above highest-anticipated snow level. Maximum of 24" (600 mm) above roof.
- Install a bird screen at the end of the intake air pipe and exhaust pipe.

Notice

Air is drawn from a different location at a minimum of 12" (300mm) from the exhaust termination. Try to minimize the length of the intake air pipe with this venting.

Concentric sidewall venting

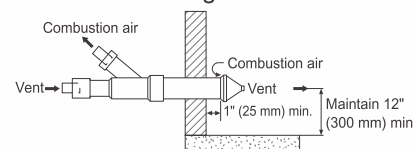

- Caution** Maintain 12" (300 mm) min. (18" (450 mm) min. for Canada) clearance above highest-anticipated snow level. Maximum of 24" (600 mm) above roof.

Connecting the Power Supply



Improperly connecting the power supply can result in electrical shock and electrocution. Follow all applicable electrical codes of the local authority having jurisdiction. In the absence of such requirements, follow the latest edition of the National Electrical Code (NFPA 70) in the USA or the latest edition of CSA C22.1 Canadian Electrical Code Part 1 in Canada. Connecting the power supply should be performed only by a licensed professional.

When connecting the power supply, follow these guidelines:

- Do not connect the electric supply until all plumbing and gas piping is complete and the water heater has been filled with water.
- Do not connect the water heater to a 220-240V AC power supply. Doing so will damage the water heater and void the warranty.
- All water heaters come with a factory-installed, 3-pronged (grounded) plug. The water heater can be plugged into any grounded electrical outlet nearby, as it requires only 2-4 Amps. It is not necessary to run a dedicated electrical line to the water heater.
- If local codes require the water heater to be wired directly, remove and discard the factory-installed plug. Install a power switch between the breaker and the water heater to facilitate end-user maintenance and servicing. Connect the water heater to a 110-120V AC at 60 Hz with a maximum of 5A rating electrical supply.
- The water heater must be electrically grounded. If using the power plug, ensure that the electrical outlet you connect the water heater to is properly grounded. If wiring the water heater directly to a power supply, do not attach the ground wire to either the gas or the water piping as plastic pipe or dielectric unions may prevent proper grounding.
- We recommend using a surge protector to protect the water heater from power surges.
- If there is a power failure in cold weather areas, the freeze prevention system in the water heater will not operate and may result in freezing of the heat exchanger. In cold weather areas where power failures are common, you must completely drain the water heater to prevent damage if the power is expected to be off for any extended period of time. A battery back-up (available at most computer retailers) may be used to supply hot water during periods of power outages. Damage caused by freezing is not covered under warranty.

After Installation

In Calibration Mode, the water heater calculates the load according to the installation circumstances (altitude, vent) and self adjust the heat capacity by itself.

To use the Calibration Mode:

- Connect the power supply.
- Press the **Power** button.
- Open more than two faucets and dispense approximately 4 gallons (15 liters) of water.
- Check that the **Water** icon is turned on.



Notice

Temperature is set to 120°F (50°C) by default.

- Press the **Menu** button.
- Enter the 4. Advanced Menu. And then, press the **Up**, **Down** and **Enter** button to enter the password 1234.

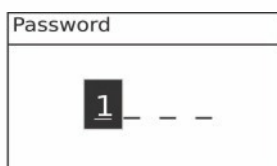
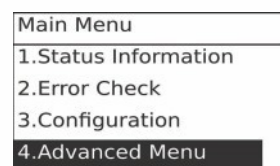

- Enter the Auto Calibration mode, check the flow rate condition, and then press Start to start.

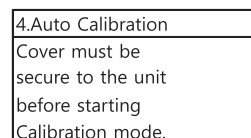
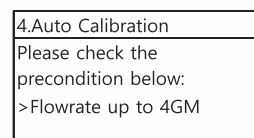

- Calibration mode operates up to 5 minutes.

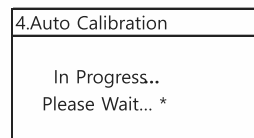

- When the mode is complete, a completion message appears and press the Enter key to exit.

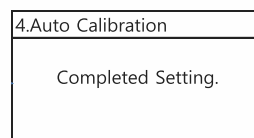

- If the message below appears after step 8, check the flow rate conditions of the product and try again.

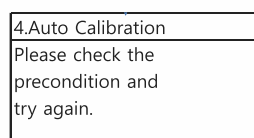

Water Heater Operation

Start-Up Wizard

When the power is applied for the first time after installing the water heater, the basic setting necessary for operation is performed.

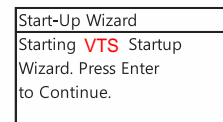

- Date Setting.

- You can set the current date.
- The date is displayed in the order of month / day / year.
- Press the **Enter** button to set the related items.

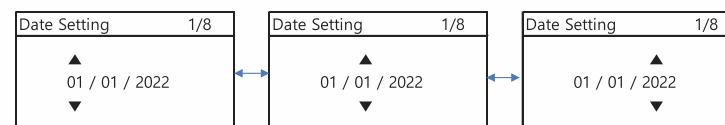

- Time Setting.

- You can set the current time.
- The time is displayed in the order of hour : minute : sec.
- Press the **Enter** button to set the related items.

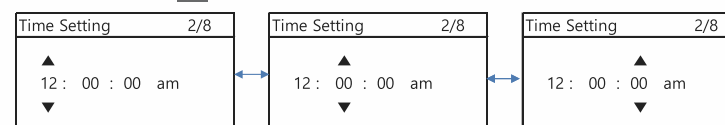

- Units Setting.

- You can set the temperature, flow rate, length display units.
- Set either °F, GPM (gallon per minute), Feet or °C, LPM (liter per minute), Meter as the display units.
- Press the **Enter** button to set the related items.

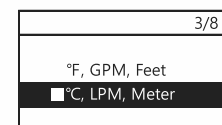

- Gas Type Setting.

- You can set the type of gas used in the product.
- Set the type of gas being used in the product.
- Press the **Enter** button to set the related items.

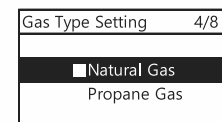

- Elevation Setting.

- You can set the elevation of the installation location of the product.
- Set the elevation of the installation location of the product.
- Press the **Enter** button to set the related items.

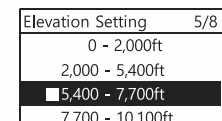

- Filter Setting.

- You can select whether or not to install the optional descale filter.
- Select whether or not to install the optional descale filter.
- Press the **Enter** button to set the related items.

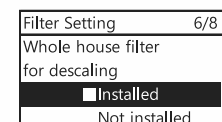

- Re-circulation type Settings. (VTP Only)

- You can set the Re-circulation mode.
- Set the Recirculation mode. (None ↔ Internal ↔ External ↔ T-valve)
- If you set External or T-valve mode, you can additionally set whether Title 24 should be used.
- Press the **Enter** button to set the related items.

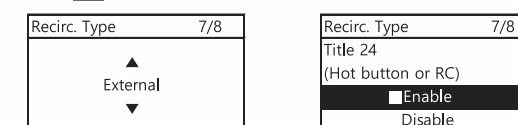

- Re-circulation time Settings. (VTP Only)

- You can set the Re-circulation operation time.
- Select the setting method to use recirculation. (Always On, Every Day, Weekday/Weekend)
- Set up to 5 timers.
- Recirculation operation is carried out for the all timer times that you set.
- Press the **Enter** button to set the related items.

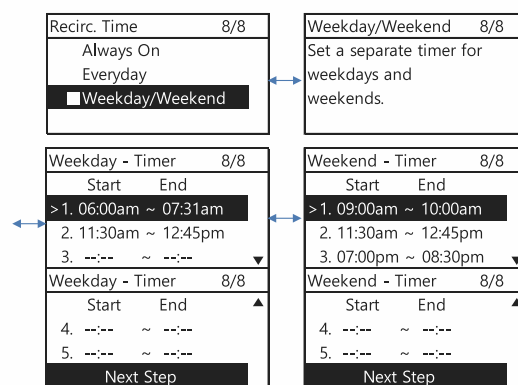

- After completing the setting, check the setting result. (Subsequent setting changes can be set in Main Menu - 3.Configuration.)

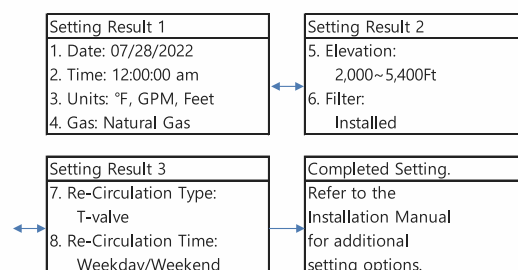

Turning the Water Heater On or Off

To turn the water heater on or off, press the **Power** button.



When the water heater is on, the water temperature which has been set recently will appear on the digital display.

Setting the Water Temperature

- Danger** If your household includes children, or elderly or disabled individuals, consider using a lower temperature setting.

- Caution** Test the temperature of the water before use.

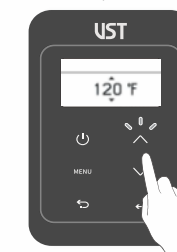

To set the water temperature, press the **Up** or **Down** buttons until the desired temperature appears on the digital display.